

## 976nm 210W High Power Fiber Coupled Diode Laser K976FN1RN-210.0W

---

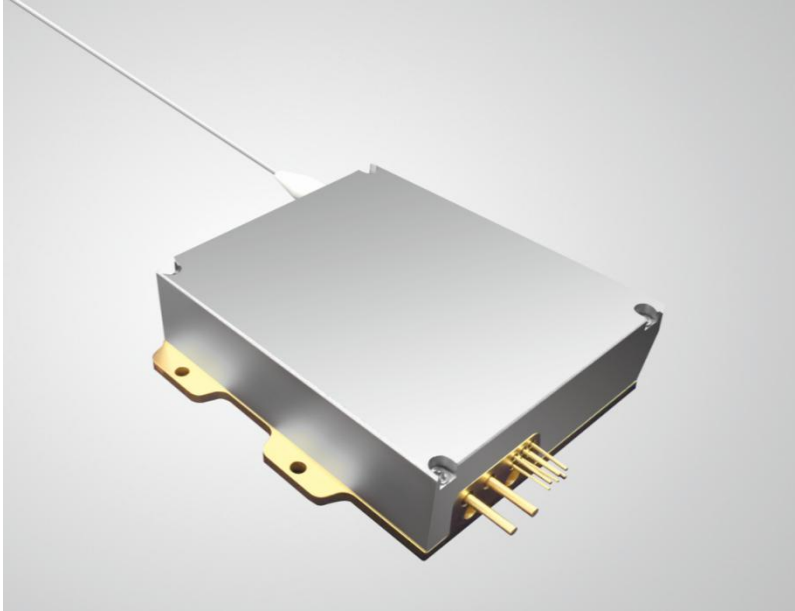

### Features:

- ◆ 976nm wavelength
- ◆ 210W output power
- ◆ 135 $\mu$ m fiber core diameter
- ◆ 0.22N.A.
- ◆ 1040nm-1200nm feedback protection

### Applications:

- ◆ Fiber laser pumping

BWT Beijing's High Power Diode Laser Modules are manufactured by adopting specialized fiber-coupling techniques, resulting in volume products with a high efficiency, stability and superior beam quality. The products are achieved by transforming the asymmetric radiation from the laser diode chip into an output fiber with small core diameter by using special micro optics. Inspecting and burn-in procedures in every aspect come to a result to guarantee each product with the reliability, stability and long lifetime.

Our research staffs are constantly improving and innovating the processing technology in the producing process, based on the professional knowledge and experience accumulated in long-terms. We are also continuously developing new products to meet customers' specific needs.

At BWT Beijing, to provide high quality products with reasonable price is our always goal.

## 976nm 210W High Power Fiber Coupled Diode Laser K976FN1RN-210.0W

Specifications(25°C)		Symbol	Unit	K976FN1RN-210.0W		
				Minimum	Typical	Maximum
<b>Optical Data<sup>(1)</sup></b>	CW-Output Power	$P_o$	W	210	-	
	Center Wavelength	$\lambda_c$	nm	966	976	986
	Spectral Width (FWHM)	$\Delta\lambda$	nm	-	-	5
	Wavelength Shift with Temperature	$\Delta\lambda/\Delta T$	nm/°C	-	~0.3	-
	Light within 0.16NA	-	%	90	-	-
<b>Electrical Data</b>	Operating Current	$I_{op}$	A	-	14	-
	Threshold Current	$I_{th}$	A	-	0.8	1.0
	Electrical-to-Optical Efficiency	$\eta$	%		50	-
	Slope Efficiency	$\eta_D$	W/A	17	-	-
	Operating Voltage	$V_{op}$	V	-	34	
<b>Fiber Data</b>	Core diameter	$D_{core}$	$\mu m$	133.5	135	136.5
	Cladding diameter	$D_{clad}$	$\mu m$	154	155	156
	Buffer diameter	$D_{buf}$	$\mu m$	300	320	340
	Numerical Aperture	N.A.	-	0.215	0.22	0.225
	Total Fiber Length	-	m	0.9	1.0	1.1
	Fiber Loose Tubing Diameter	-	$\mu m$	-	900	-
	Minimum Static Bending Radius	-	mm	80	-	-
	Minimum Dynamic Bending Radius	-	mm	124	-	-
Connector	-	-	-	None	-	
<b>PD Date</b>	PD Current	$I_{mo}$	$\mu A$	-	-	-
<b>Thermistor Data<sup>(2)</sup></b>	Thermistor	$R_t$	(K $\Omega$ )/ $\beta(25^\circ C)$	-	-	-
<b>Feedback Isolation</b>	Wavelength Range	$\lambda$	nm	1040	-	1200
	Isolation	-	dB	30	-	-
<b>Others</b>	Operating Case Temperature	$T_{op}$	°C	20	-	35
	Storage Temperature(Non-operating)	$T_{st}$	°C	-20	-	+70
	ESD	-	V	-	-	500
	Lead Soldering Temp	-	°C	-	-	260
	Lead Soldering Time	-	sec	-	-	10
	Relative Humidity	-	%	15	-	75

(1) Data measured under operation output at 210W.

(2)  $R_T = R_0 \cdot \exp(\beta(1/T - 1/T_0))$ , ( $T_0 = 25^\circ C = 298K$ ).

**976nm 210W High Power Fiber Coupled Diode Laser  
K976FN1RN-210.0W**

**Characteristics**

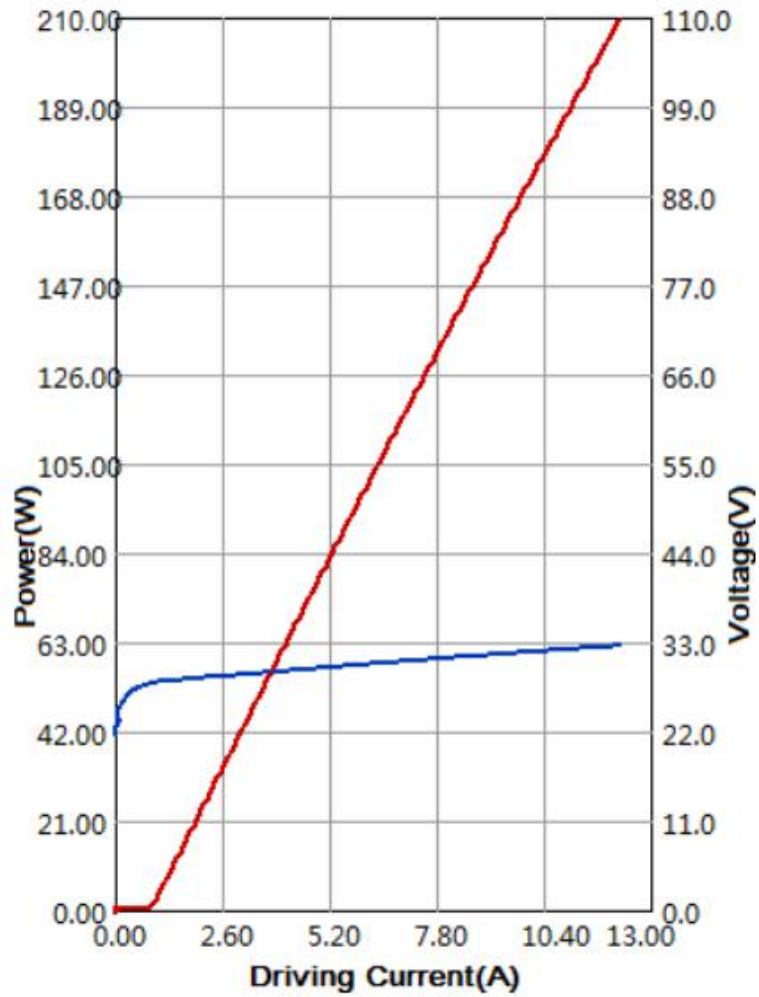

## 976nm 210W High Power Fiber Coupled Diode Laser K976FN1RN-210.0W

### Package Dimensions (mm)

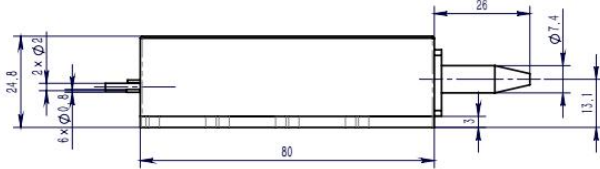

Pins	Function
1	LD ( + )
2	LD ( - )

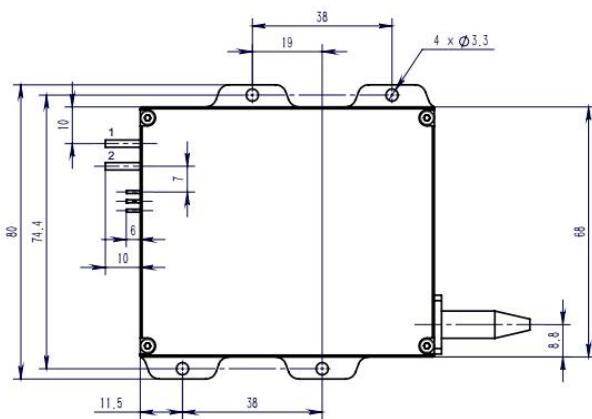

\* Optional function: thermistor, aiming beam, PD

### OPERATING NOTES

- ◆ Avoid eye exposure to direct or scattered radiation.
- ◆ ESD precautions must be taken.
- ◆ Please connect pins to wires by solder instead of using socket when operation current is higher than 6A.
- ◆ Soldering point should be close to the root of the pins. Soldering temperature should be lower than 260°C and time shorter than 10 second.
- ◆ Use constant current power supply. Avoid surge current.
- ◆ Laser diode must be used according to the specifications.
- ◆ Laser diode must work with good cooling.
- ◆ Operation temperature is 20°C~ 35°C. ( case temperature )
- ◆ Storage: -20°C~ +70°C, all pins short-circuit.



Information and specifications contained herein are deemed to be reliable and accurate. BWT Beijing reserves the right to change, alter or modify the design and specifications of these products at any time without notice.